



**MONTERINGSANVISNING · INSTALLATION INSTRUCTIONS
MONTAGEANLEITUNG · INSTRUCTIONS DE MONTAGE**

Saab 900 M95-, Saab 9-3 B204, B234

Cruise Control

Accessories Part No.	Group	Date	Instruction Part No.	Replaces
400 130 555 400 130 563	3:68-19	May 02	47 11 438	47 11 438 Jul 00

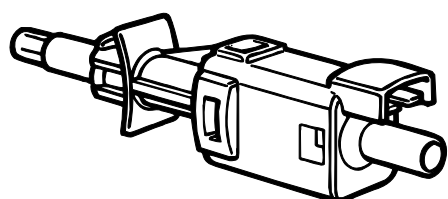
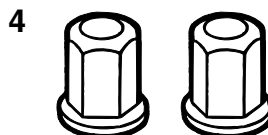
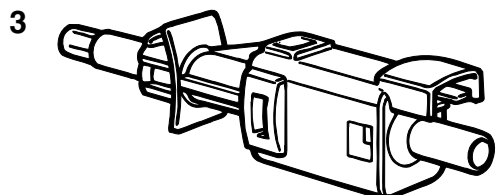
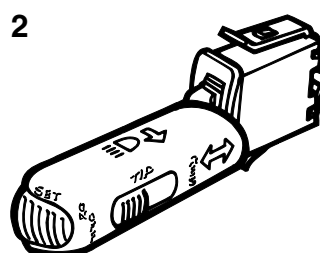
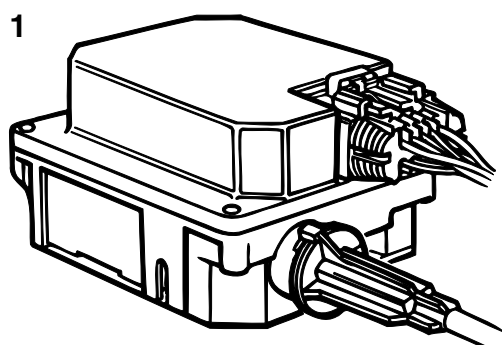

D930A004

- 1 Control module
- 2 Selector switch
- 3 Brake and clutch switches
- 4 Retaining nuts
- 5 Clip

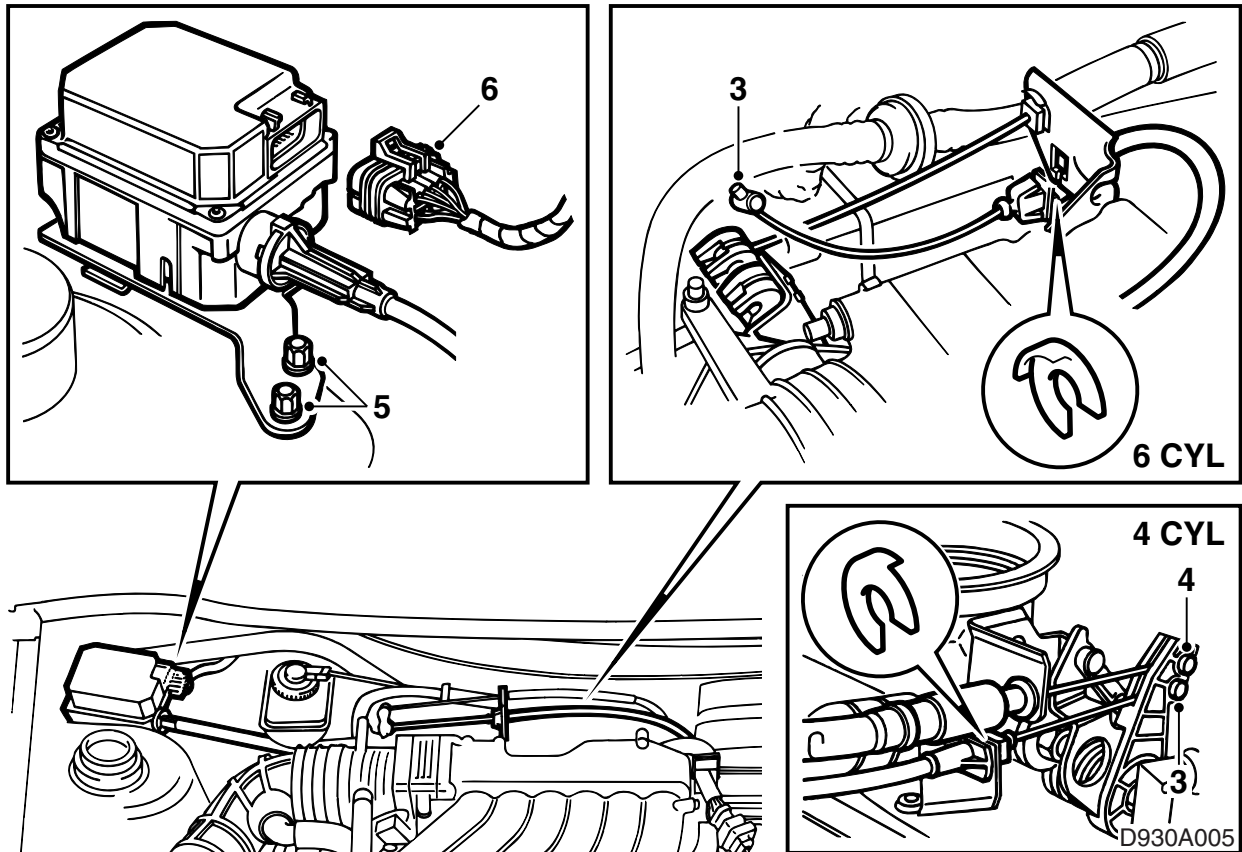

- 1 Loosen the air silencer (resonator) and move it aside. Mind the O-ring! (4-cyl)
- 2 Hold the Cruise Control unit in your hand and insert the cable under the crankcase ventilation hoses behind the dipstick pipe and along the throttle body lever (4-cyl).
For 6-cylinder engines, run the Cruise Control cable in front of the bulkhead.
- 3 Detach the throttle cable from the lever and connect the Cruise Control unit cable to the lever notch second from the top, see Fig.

Important

Insert the cable stop until it bottoms in the lever notch (a click sound should be audible).

- 4 Secure the cable sheathing to the bracket with the clip and connect the throttle cable to the uppermost lever notch. Secure the cables with cable ties in front of the throttle body (4-cyl) or to the wiring in front of the bulkhead (6-cyl).
- 5 Fit the Cruise Control unit.
- 6 Detach the wiring harness provision from the bulkhead and plug the 10-pin connector into the Cruise Control unit.
- 7 Fit the air silencer (resonator). Note the position and condition of the O-ring.

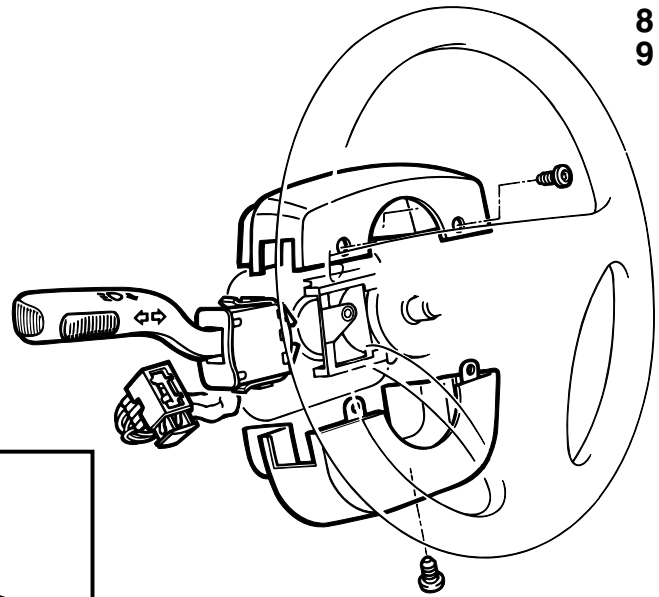
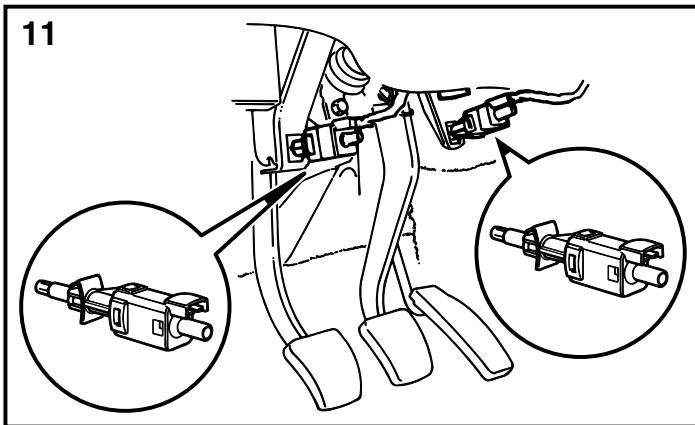
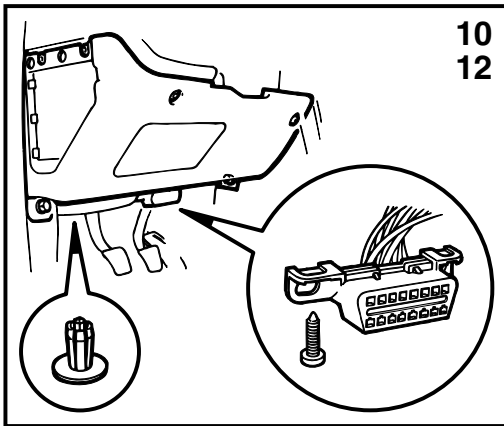

D930A006

- 8 Extract the steering wheel to its outermost position and remove the steering wheel cowling sections. Unplug the Cruise Control unit connector, unsnap and remove the direction indicator switch.
- 9 Fit the Cruise Control unit selector switch, plug in the connector and fit the steering wheel cowling sections.
- 10 Remove the lower section of the dashboard.
- 11 Disconnect the clutch and brake switch wiring. Fit the brake and clutch switches to the brackets on the pedal assembly.

- Car speed will drop to approx. 40 km/h, press "RES". The car accelerates and returns to a speed of 50 km/h.
- Press "SET" and hold the button for approx. 2 seconds.

The car speed increases and maintains the previous speed from when the "SET" button was released.

Important

Make sure the switches properly snap into place.

Connect the wiring.

- 12 Refit the lower section of the dashboard.
- 13 Drive the car and test the switch and pedal switch functions:
 - Drive at a speed of approx. 50 km/h and press "SET". Release the accelerator pedal; the car should maintain a constant speed.
 - Press lightly on the brake pedal to disengage Cruise Control.
 - Car speed will drop to approx. 40 km/h, press "RES". The car accelerates and returns to a speed of 50 km/h.
 - Press lightly on the clutch pedal to disengage Cruise Control.