



MONTERINGSANVISNING · INSTALLATION INSTRUCTIONS
MONTAGEANLEITUNG · INSTRUCTIONS DE MONTAGE

Saab 900 CV M95-, Saab 9-3 CV

Rear spoiler

Accessories Part No.	Group	Date	Instruction Part No.	Replaces
400 109 021	9:84-03	Jun 00	49 12 978	49 12 978 Aug 98

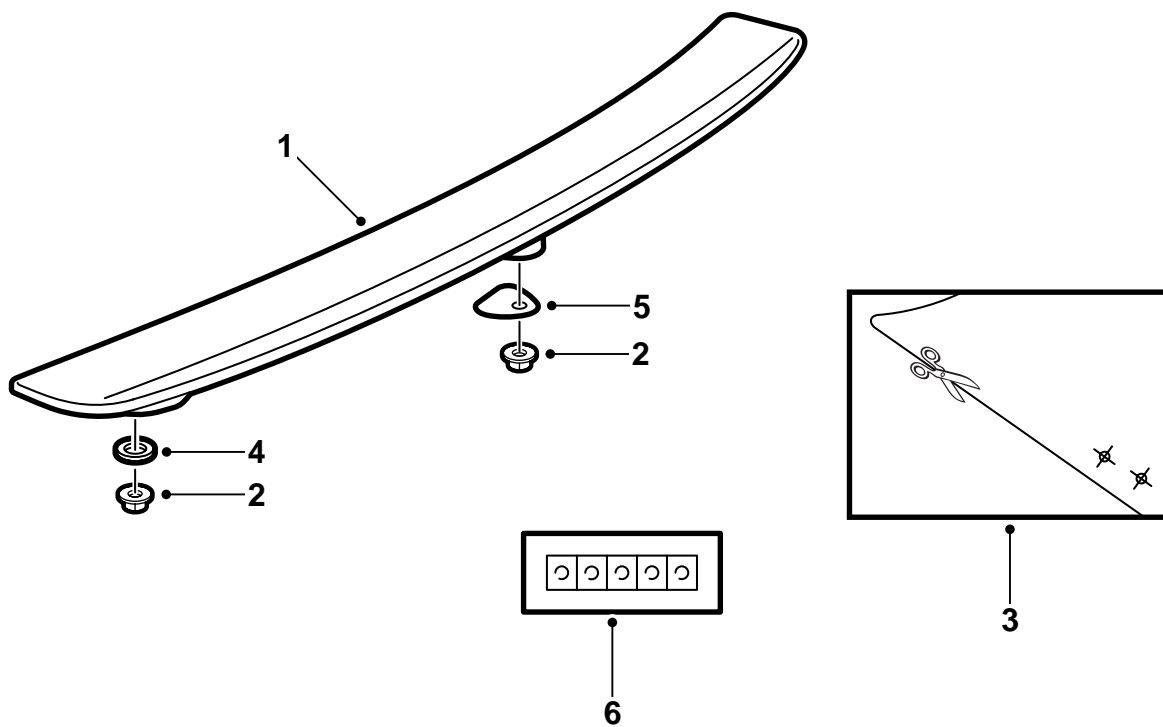

D980A060

- 1 Spoiler (1)
- 2 Nut (5)
- 3 Drilling template (1)
- 4 Seal, round (4)
- 5 Seal, centre foot (1)
- 6 Zinc washer (5)

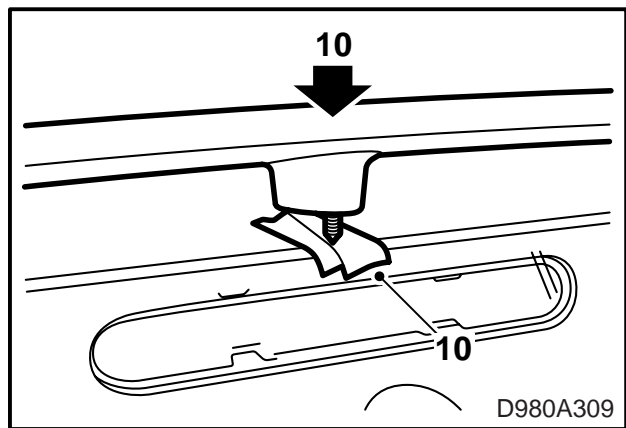
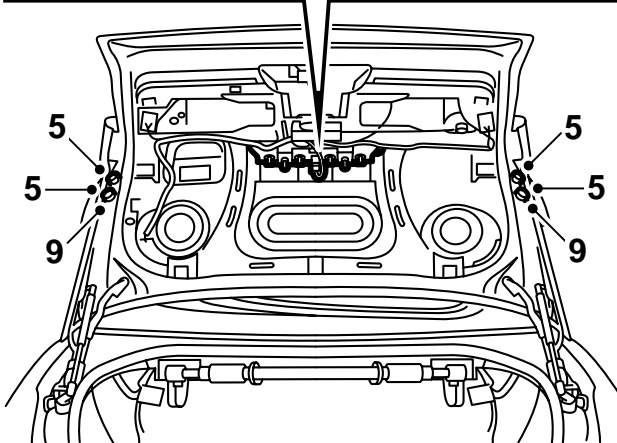
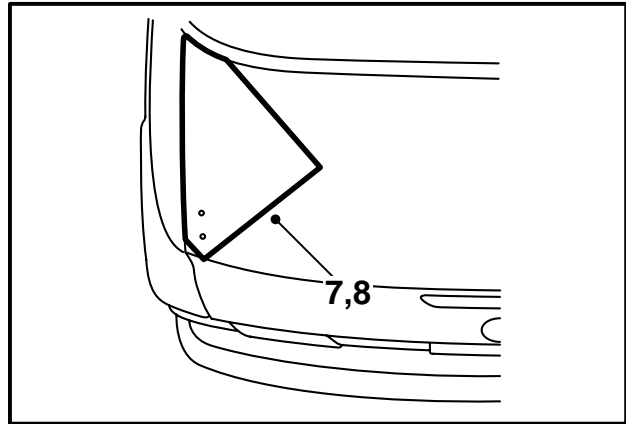
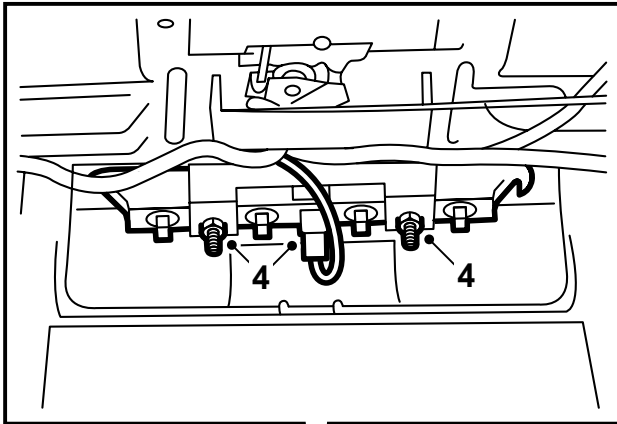

The spoiler is treated with black primer and consequently prepared for painting.

- 1 Paint the spoiler the same colour as the car. See "Painting instructions for pre-primed PUR-RIM plastic" in these mounting instructions.
- 2 Open the hatch.
- 3 Remove the trim on the inside of the hatch.
- 4 Remove the centre brake light.
- 5 Remove the rubber bushes. Note the number of turns the bushes are screwed in.
9-3: Remove the rubber plugs.
- 6 Cut the template out and position it as described in the instructions on it.
- 7 Mark the positions of the outer holes with a centre punch.

Important

Take pains to be accurate.

- 8 Drill an 8 mm hole according to the markings.
900: Drill through the lower plate as well.
- 9 **900:** Drill through the lower plate only from below with a 16 mm bit according to the markings from drilling the previous step.

Important

Use a drill stop to avoid drilling through the upper plate.

- 10 Use masking tape to mark the approximate position of the centre hole. Fit the spoiler in place and press it down in the middle. Lift the spoiler away. The screw in the centre of the spoiler should have left a mark in the masking tape.

- 11 Drill holes according to the middle marking. Use a 8 mm drill bit.
- 12 Protect the drilled holes from corrosion as follows:
 - Deburr the holes and remove loose cuttings and flakes of paint.
 - Apply Standox 1K Primer Filler or other equivalent product.
 - Apply finish paint.
 - Affix zinc tape over the holes and press down with a screwdriver so that the tape folds down over the edges.

D980A309

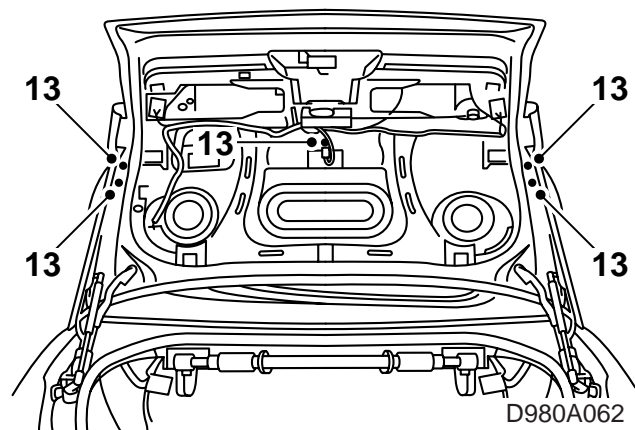
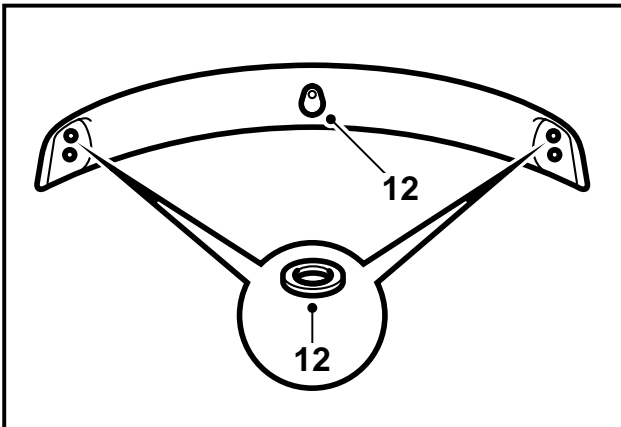

D980A062

- 13 Fit the seals and place the spoiler in position on the hatch.
- 14 Fit the nuts holding the spoiler.
Tightening torque: 6 Nm (4.5 lbf ft)

Important

Take care to ensure that the nuts do not fall into the hatch.

- 15 Fit the rubber plugs and rubber bushes. Adjust the bushes as noted earlier.
900: Rubber plug 95 50 476 (x2) must be ordered separately.
- 16 Refit the centre brake light.
- 17 Refit the trim on the inside of the hatch.

Painting instructions for preprimed PUR-RIM plastic.

- During the painting process the spoiler should be placed in such a way that it will not be deformed.
- The temperature must not exceed +40°C (104°F).
- The spoiler is preprimed as delivered from the supplier.
- Clean gloves should be worn when handling the spoiler.

Drying time

70 minutes at 40°C (104°F).

Preparations

- For best results, pore-filling paint should be applied.
- Rub down the primed surfaces thoroughly. Use 3M 1200 or 800 abrasive paper.