



**MONTERINGSANVISNING · INSTALLATION INSTRUCTIONS  
MONTAGEANLEITUNG · INSTRUCTIONS DE MONTAGE**

## Saab 9-3 B205E

### Tuning Kit

Accessories Part No.	Group	Date	Instruction Part No.	Replaces
400 130 027 400 130 035	9:29-04	Dec 00	53 81 918	53 81 918 Nov 00

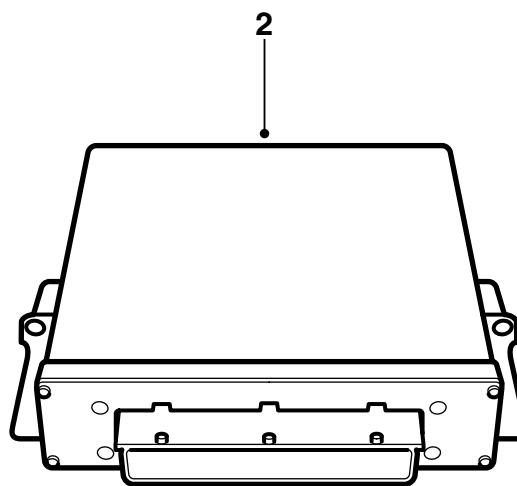
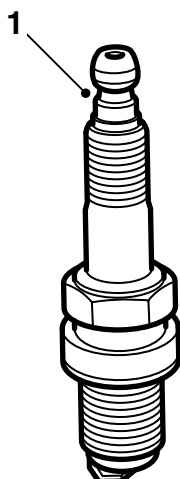

D920A001

- 1 Spark plugs (4 pcs.)
- 2 Control module

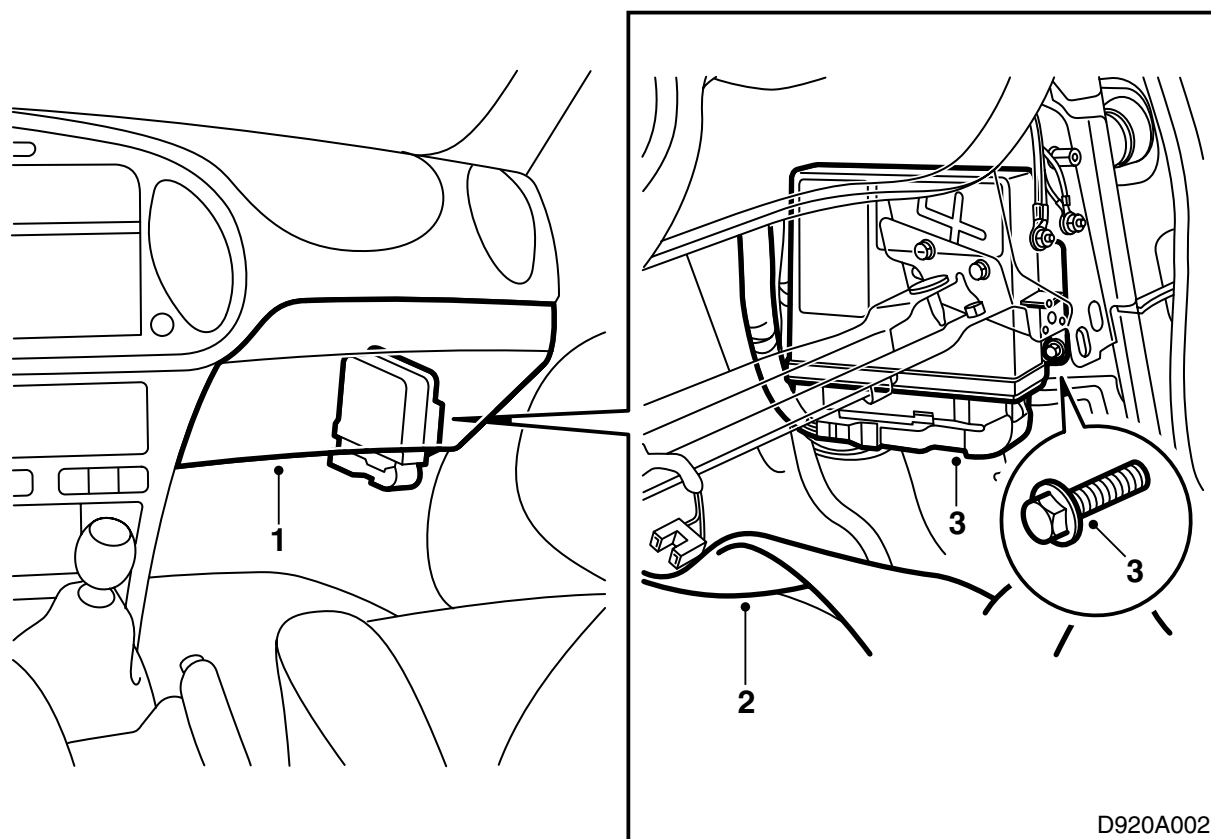

- 1 Remove the glove box.
- 2 Fold the carpet aside.
- 3 Unplug the connector and remove the control module.
- 4 Fit the control module.
- 5 Plug in the connector.
- 6 Fold the carpet back into place.
- 7 Fit the glove box.

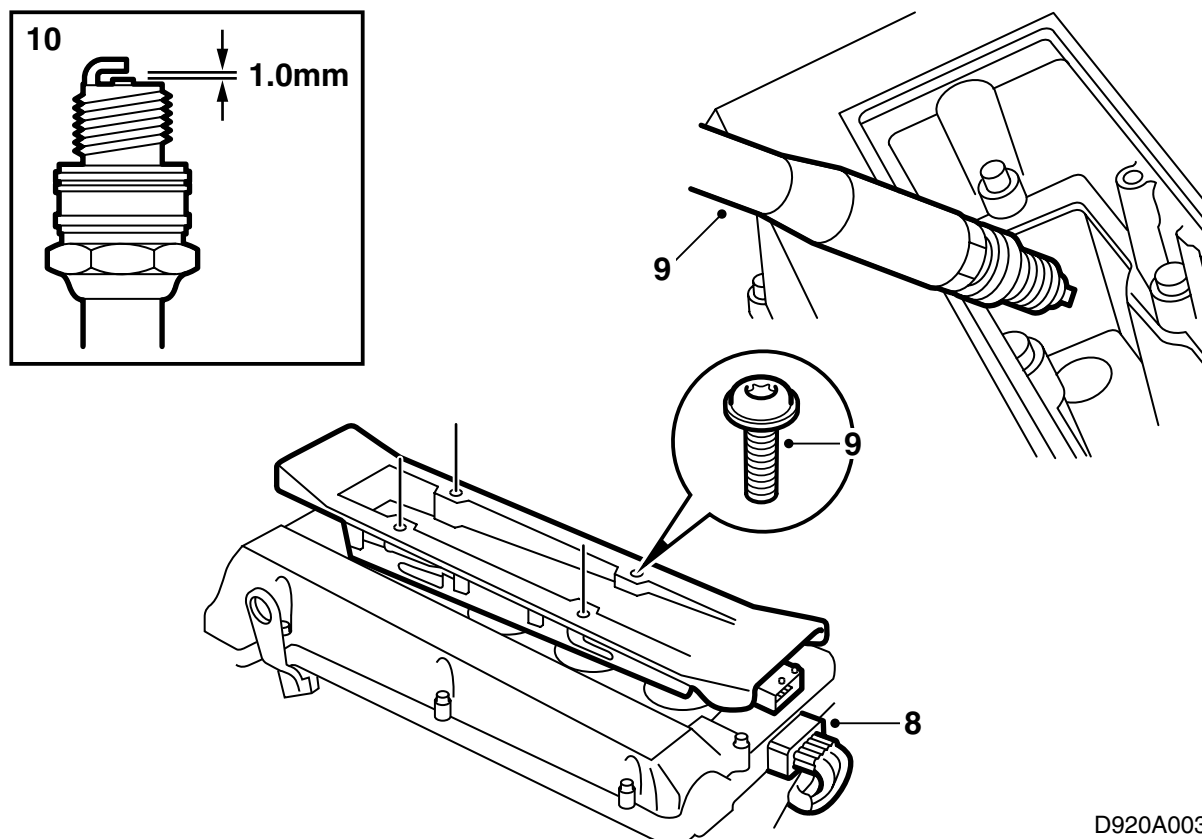

D920A003

- 8 Unplug the ignition discharge module and unscrew the 4 bolts.
- 9 Remove the ignition discharge module and the spark plugs.
- 10 Check the new spark plug gaps. They should be 1.0-1.1 mm.
- 11 Apply Molykote 1000 (part no. 30 20 271) or equivalent to the threads on the new spark plugs and fit them the plugs.  
**Tightening torque 27 Nm (20 lbf ft).**
- 12 Lubricate the rubber seals on the ignition discharge module spark plug connections with Krytox (part no. 30 19 312) and fit the module.  
**Tightening torque 11 Nm (8 lbf ft).**
- 13 Plug in the connector to the ignition discharge module.
- 14 Co-program the control module with the TWICE control module and the MIU using the diagnostic tool. Turn the ignition to ON, select Body, TWICE and the "Immobilizer" menu. It takes about 10 seconds to program the immobilizer.

---

### Important

There may be trouble codes present in the engine management system after programming. Clear them.

---

Check that the engine can be started.

- 15 **Sweden:** Fill in the certificate included with the installation instructions and present it to the customer.

---

### Important

A new registration test must be carried out on the car due to increased engine output.

---

The certificate must be presented at the new registration test.

- 16 Give these installation instructions and "TUNING KIT CERTIFICATE FOR SAAB 9-3" to the customer.