



**MONTERINGSANVISNING · INSTALLATION INSTRUCTIONS  
MONTAGEANLEITUNG · INSTRUCTIONS DE MONTAGE**

**Saab 9-3 4D/CV M03-**

(EC 94/20, e4 00 1958)

(EC 94/20, e4 00 3703)

Towbar, removable

Accessories Part No.	Group	Date	Instruction Part No.	Replaces
12 804 701 13 296 523 32 026 047	9:86-02	Jun 08	12 797 882	Mar 08

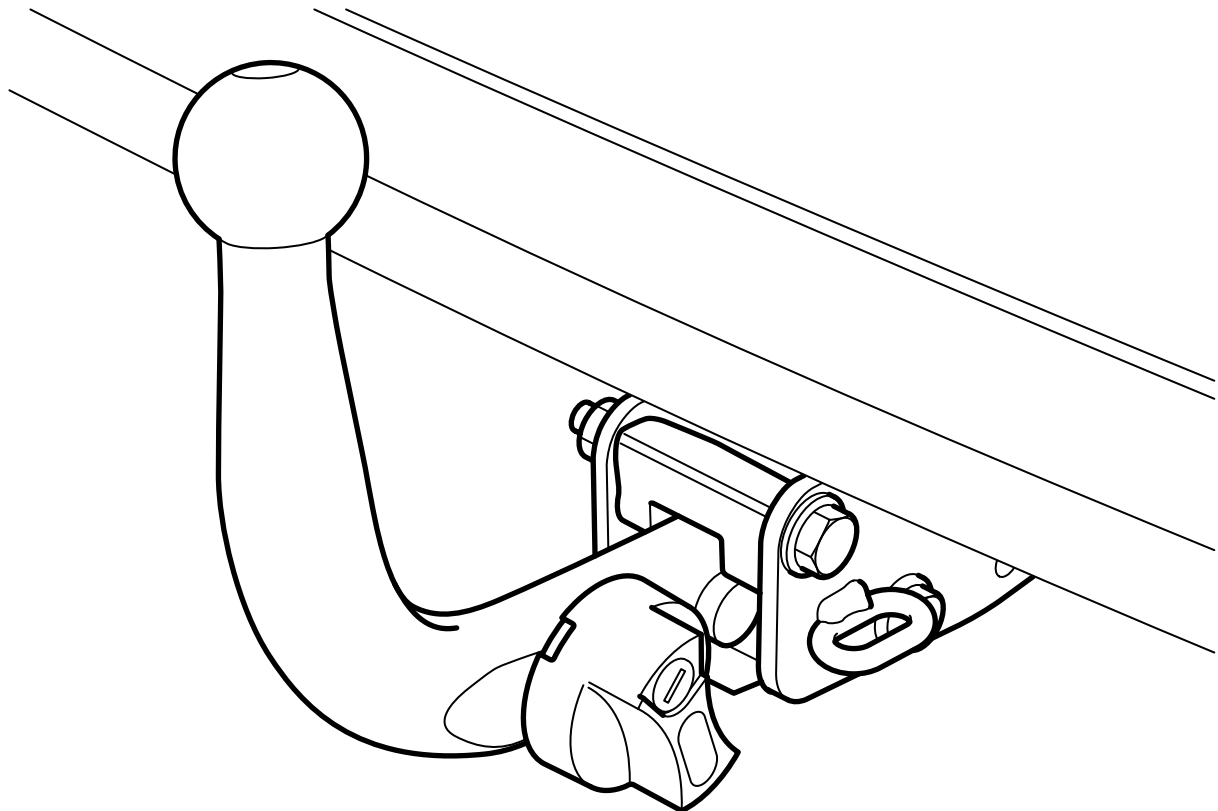

F980A020

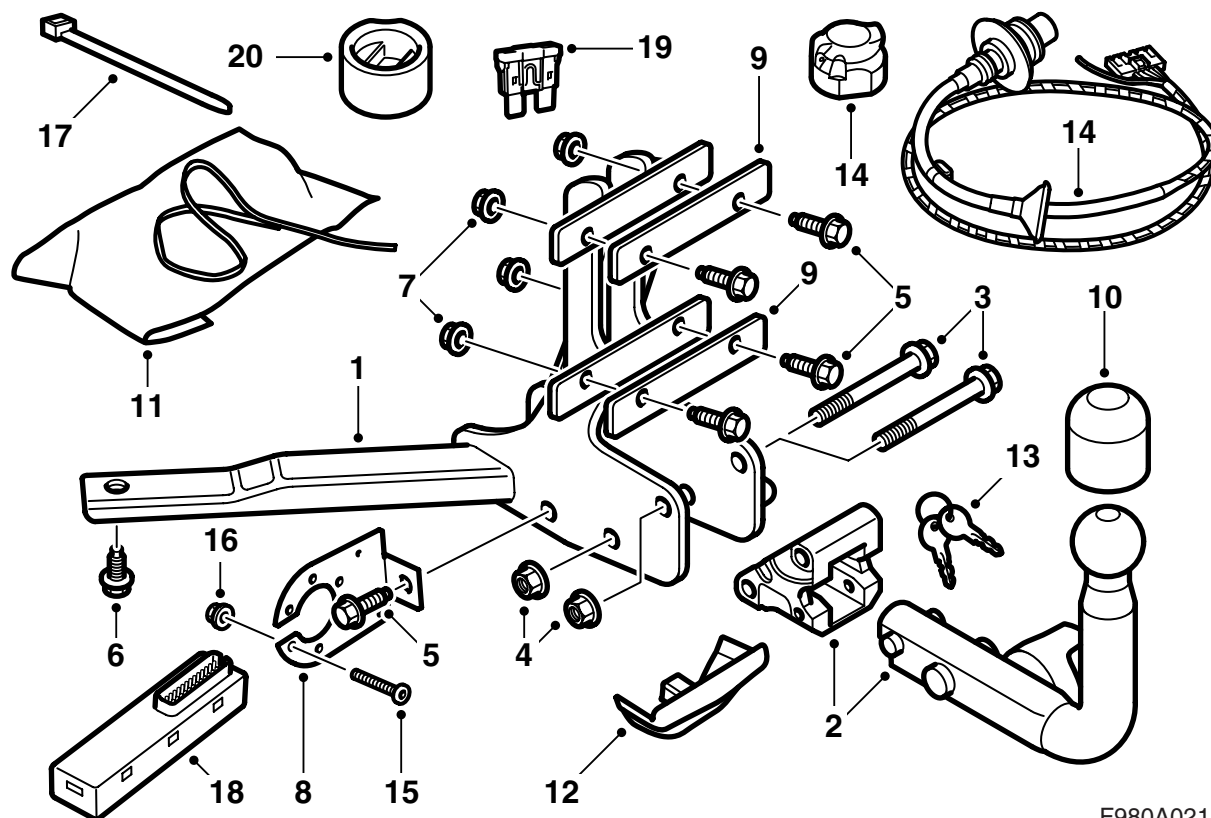

F980A021

- 1 Body bracket
- 2 Ball unit
- 3 Screw (x2)\_12x100\_10.9
- 4 Nut (x2)\_M12\_-10-
- 5 Screw (x5)\_10x30\_10.9
- 6 Screw (x2)\_10x20\_10.9
- 7 Nut (x5)\_M10\_-10-
- 8 Socket holder plate
- 9 Reinforcing plate (x2)
- 10 Ball guard
- 11 Storage bag
- 12 Cover (purchased separately)
- 13 Key (x2)
- 14 Wiring harness (13-pin)
- 15 Screw (x3)
- 16 Nut (x3)
- 17 Cable tie (x4)
- 18 Electronic module
- 19 Fuse
- 20 Protective collar

**Note**

Always check national legislation and regulations regarding mounting a towing bracket. Ensure that all requirements are complied with.

The towing bracket fulfils the requirements of 94/20/EEC.

**Maximum permitted trailer weight:**

Braked trailer: 1600 kg (3500 lbs.)

Trailer without brakes: 50% of the towing vehicle's weight (vehicle in running order), but no more than 750 kg (1650 lbs).

**Max. permissible towball pressure:** 75 kg

**Maximum D-value:**

8.91 kN (EC 94/20, e4 00 1958)

9.14 kN (EC 94/20, e4 00 3703)

---

**Important**

The car must be inspected after the towing bracket is mounted. Show these instructions at the inspection.

---

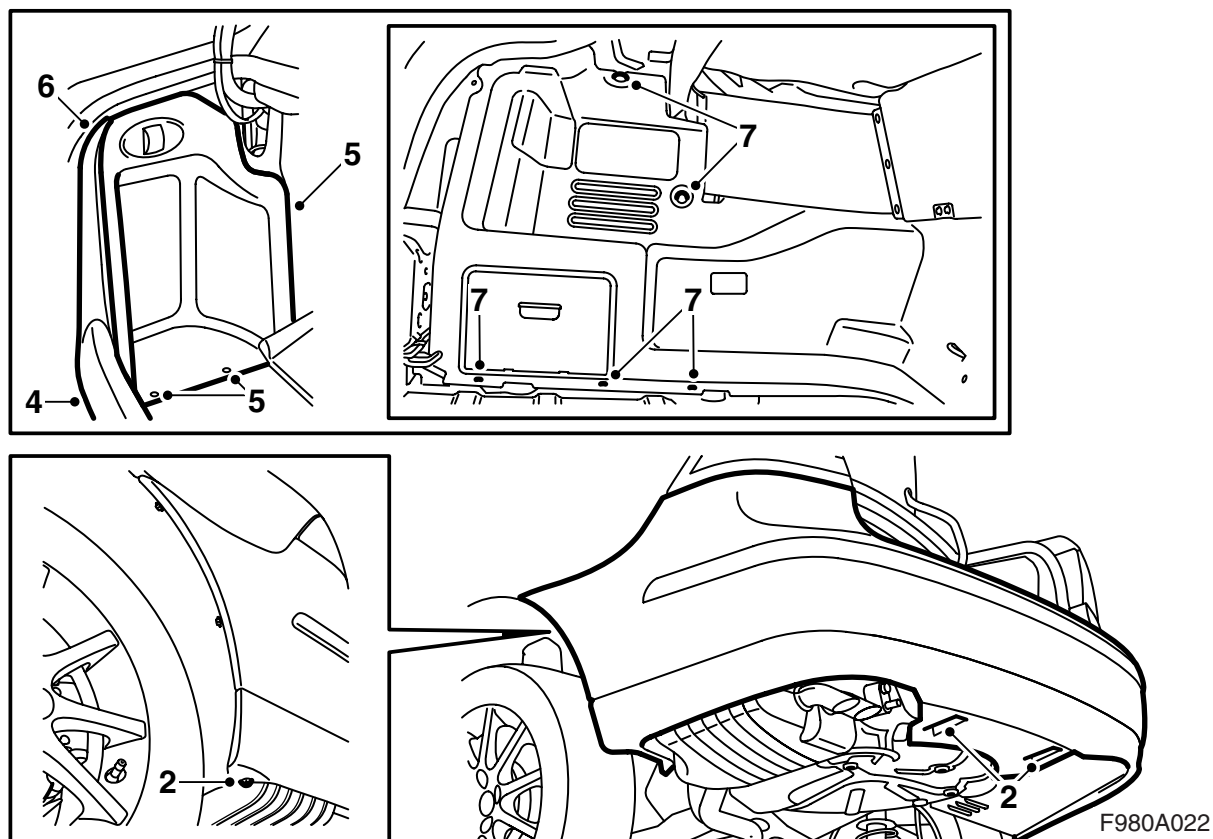

- 1 Raise the car.
- 2 Remove the two nuts holding the rear bumper air shield against the body and the two bolts holding the bumper shell against the wheel housings.
- 3 Lower the car and open the boot lid.  
**CV:** Remove the carpet on the luggage compartment floor.
- 4 Remove the luggage compartment scuff plate.
- 5 **4D:** Remove the hatch in the luggage compartment left-hand side trim and lower the hatch on the right-hand side.
- 6 Remove the side scuff plate on the left-hand side.
- 7 Remove the clips for the left-hand side trim and fold the trim aside.  
**CV:** Unhook the strap on the rear side of the side trim and remove the connector from the luggage compartment lighting. Remove the side trim.

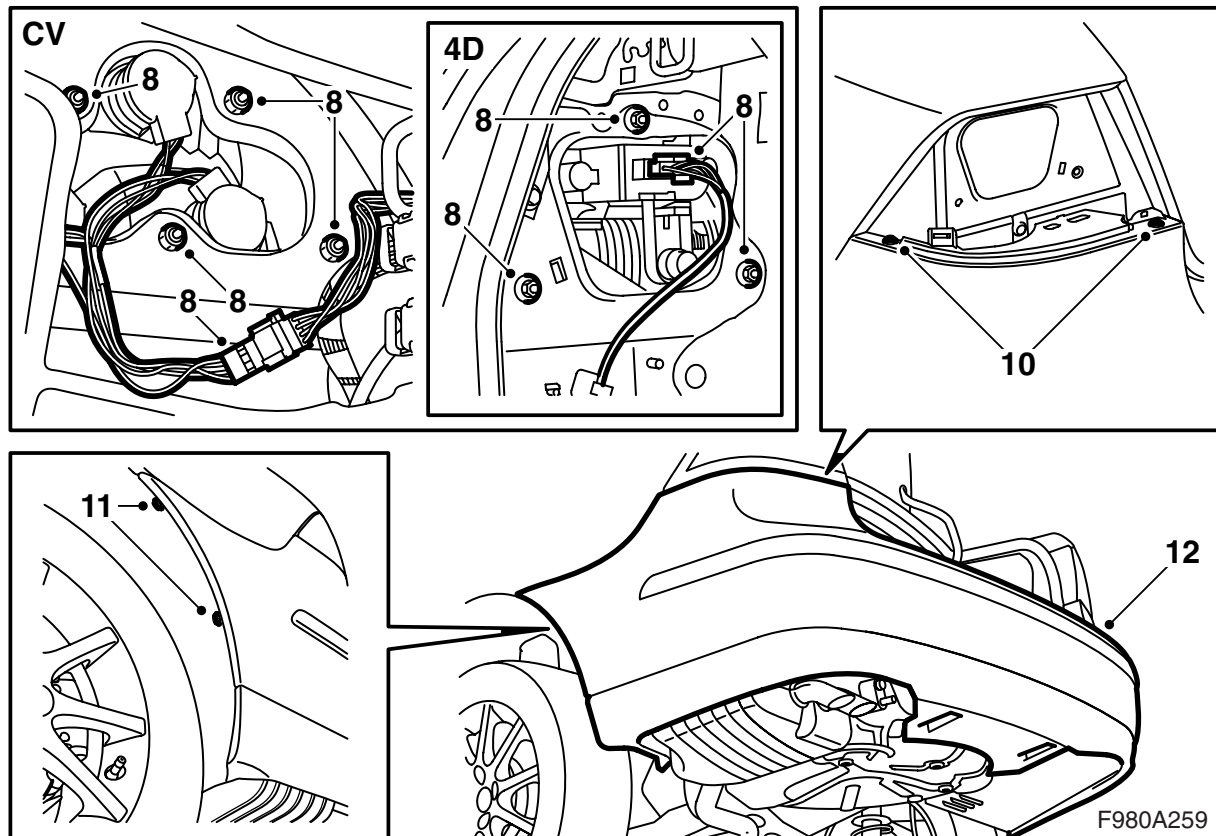

F980A259

- 8 Remove the rear lamp clusters.
- 9 **SPA:** Unplug the connector.
- 10 Remove the bumper shell bolts that are located below the rear lamp clusters.
- 11 Remove the bumper bolts at the wheel housings.
- 12 Remove the bumper shell by pulling the sides outwards and then pulling the bumper shell rearwards.

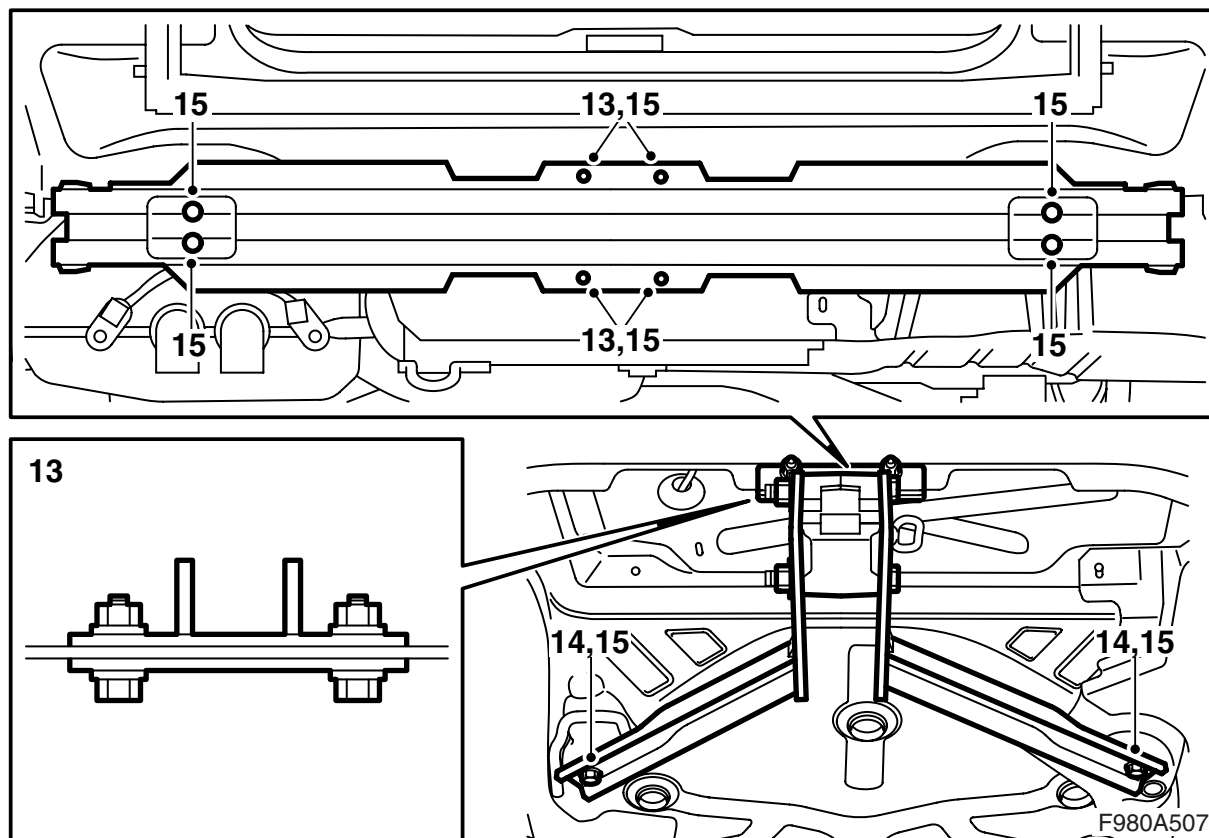

- 13 Secure the towbar with bolts and nuts together with the reinforcements in the four holes which are in the bumper member and raise the car.
- 14 Fasten the towing bracket in the floor under the spare wheel well.
- 15 Tighten the bumper member mountings against the body and the bolts and nuts holding the towing bracket against the bumper member and floor.

**Tightening torque, bumper member to body  
50 Nm (37 lbf ft)**

**Tightening torque, towing bracket to bumper  
member 50 Nm (37 lbf ft)**

**Tightening torque, towing bracket to floor  
50 Nm (37 lbf ft)**

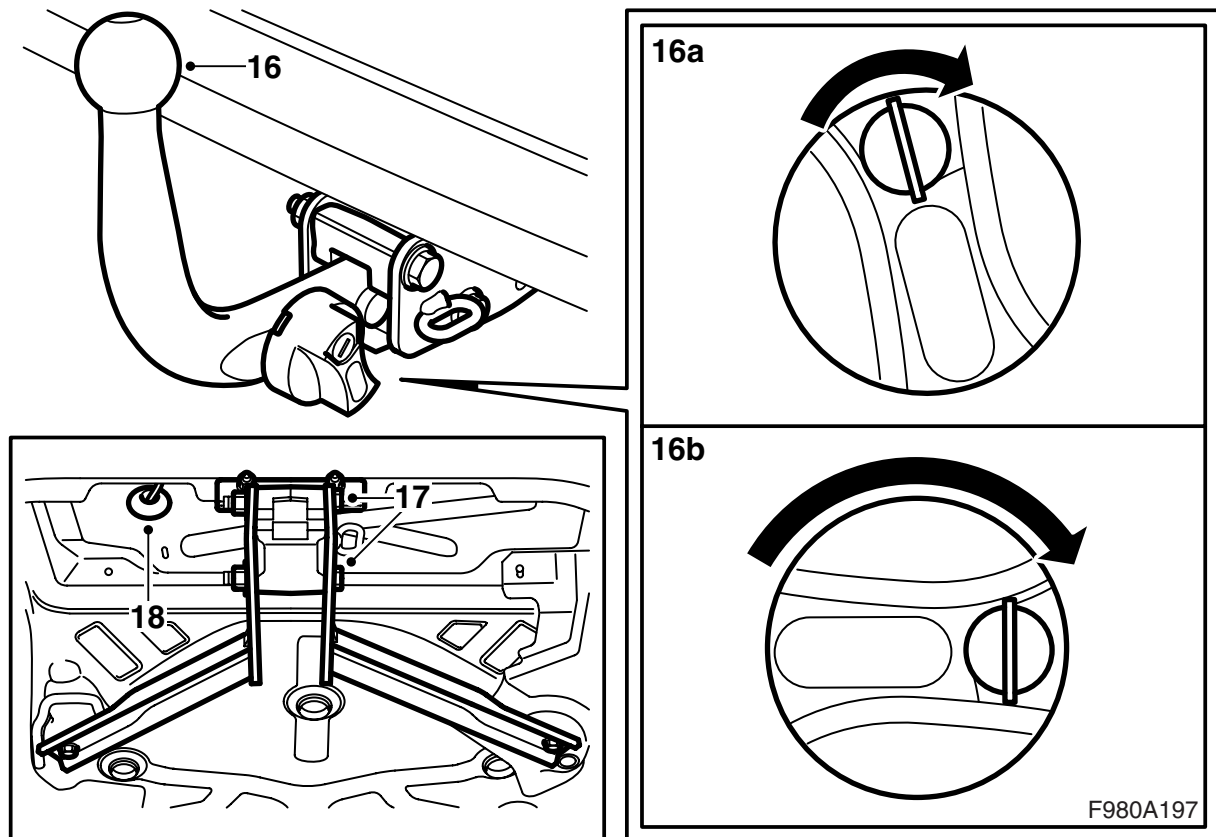

- 16 Remove the ball unit from the bracket by
- inserting the key in the lock and turning it clockwise
  - pressing in the knob and turning it clockwise until it meets resistance and an audible "click" is heard
  - lifting the ball unit up and pulling it rearwards.
- 17 Fit the ball unit bracket to the body bracket.

---

### Important

Insert the screws from the right.

---

**Tightening torque 90 Nm (66.5 lbf ft)**

- 18 Remove the rubber grommet.

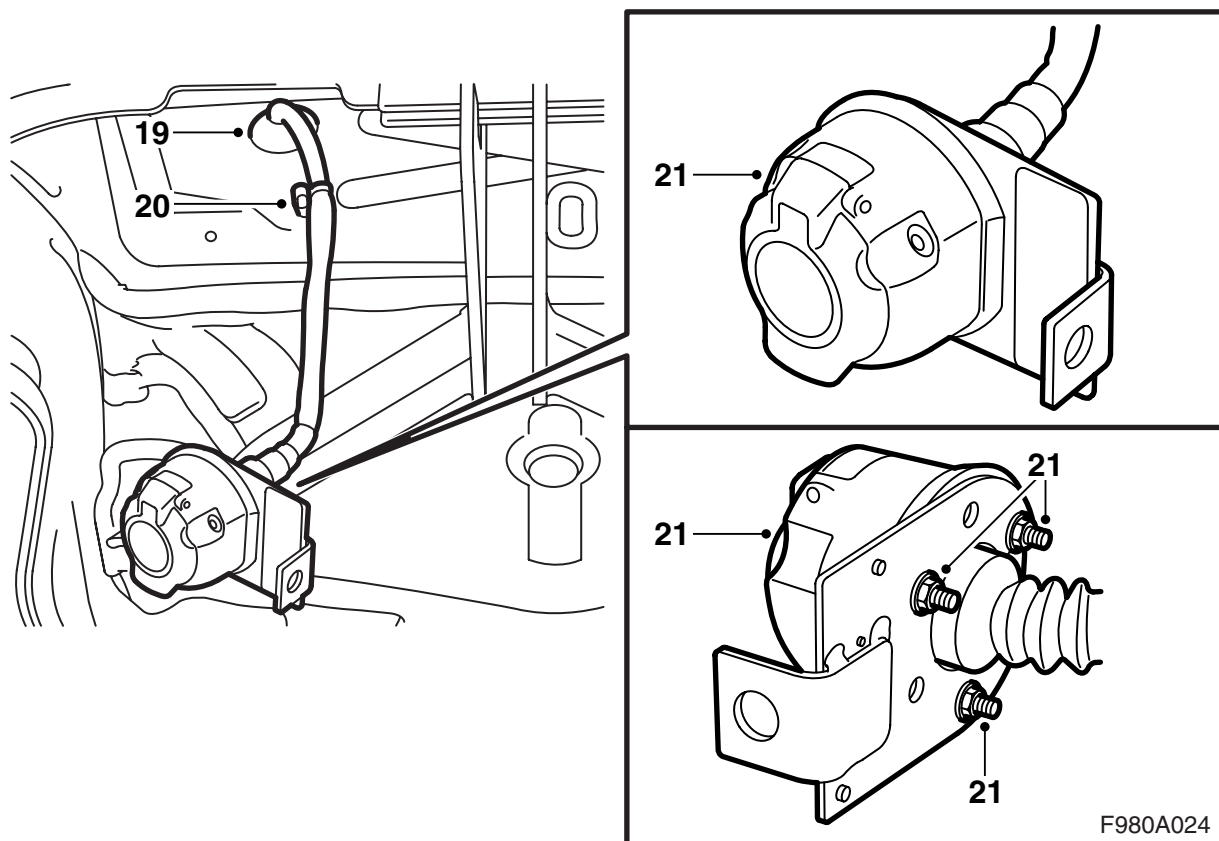

- 19 Insert the wiring harness through the hole in the body.
- 20 Fasten the wiring harness to the right-hand weld screw on the left-hand side of the towing bracket.
- 21 Fit the 13-pin connector to the connector holder plate. The cover should open upward.

---

**Important**

The seal between the connector and the connector holder plate must be correctly mounted and should not be folded in anywhere.

---



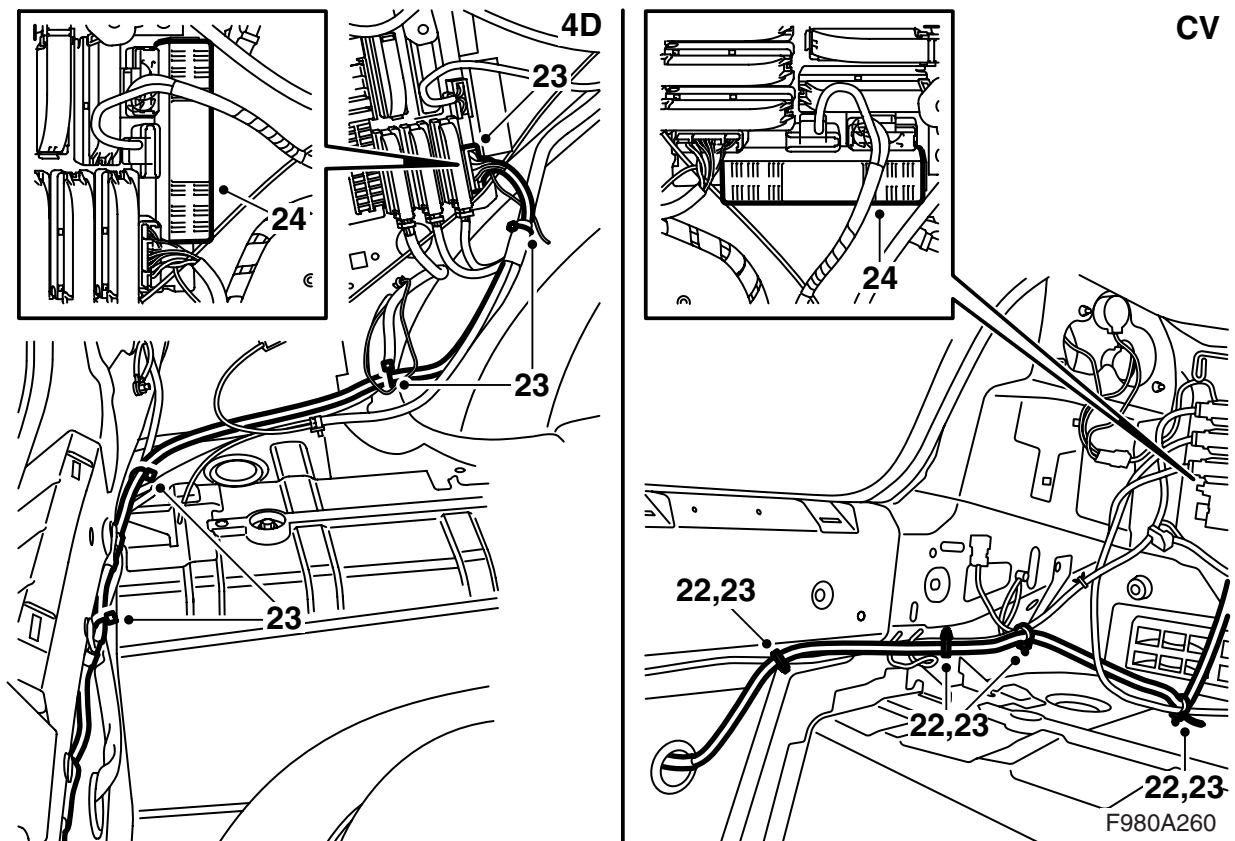

- 22 Lower the car and run the wiring harness along the other wiring harnesses towards the left-hand side of the car and to the REC.
- 23 Plug the wiring harness connector into the REC and secure the wiring harness with 4 cable ties.

### Important

The blue/white (BU/WH) cable which is not connected in the connector must not be used, but must be secured together with the wiring harness in the nearest cable tie.

- 24 Fit the kit's electronic module in the REC and fit the fuse in position 8 in the REC.

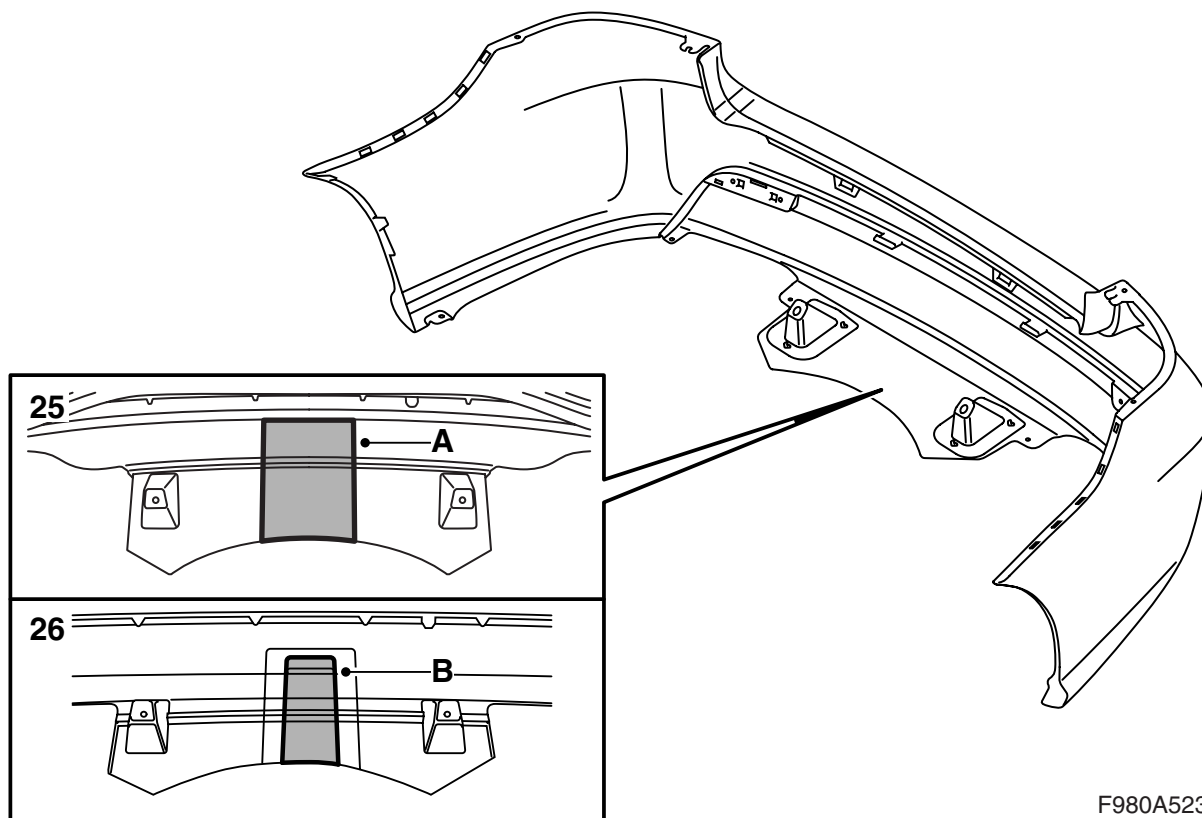

F980A523

**25 M03-07, cars without bumper skirt**

Cut/saw from the inside of the bumper, inside the reinforcement ribs in accordance with the marking (A).

**⚠ WARNING**

Use of a saw and knife entails a risk of injury. Exercise caution when cutting. Check that the bumper shell is stably positioned before beginning to cut. Use personal protection equipment, such as protective gloves, safety goggles and hearing protection.

**Note**

The cut-out may need to be adapted to the towbar after fitting. Check that there is a small amount of play between towbar and bumper.

**26 M03-07, cars with bumper skirt**

Cut/saw from the inside of the bumper, inside the reinforcement ribs in accordance with the marking (B).

**⚠ WARNING**

Use of a saw and knife entails a risk of injury. Exercise caution when cutting. Check that the bumper shell is stably positioned before beginning to cut. Use personal protection equipment, such as protective gloves, safety goggles and hearing protection.

**Note**

The cut-out may need to be adapted to the towbar after fitting. Check that there is a small amount of play between towbar and bumper.

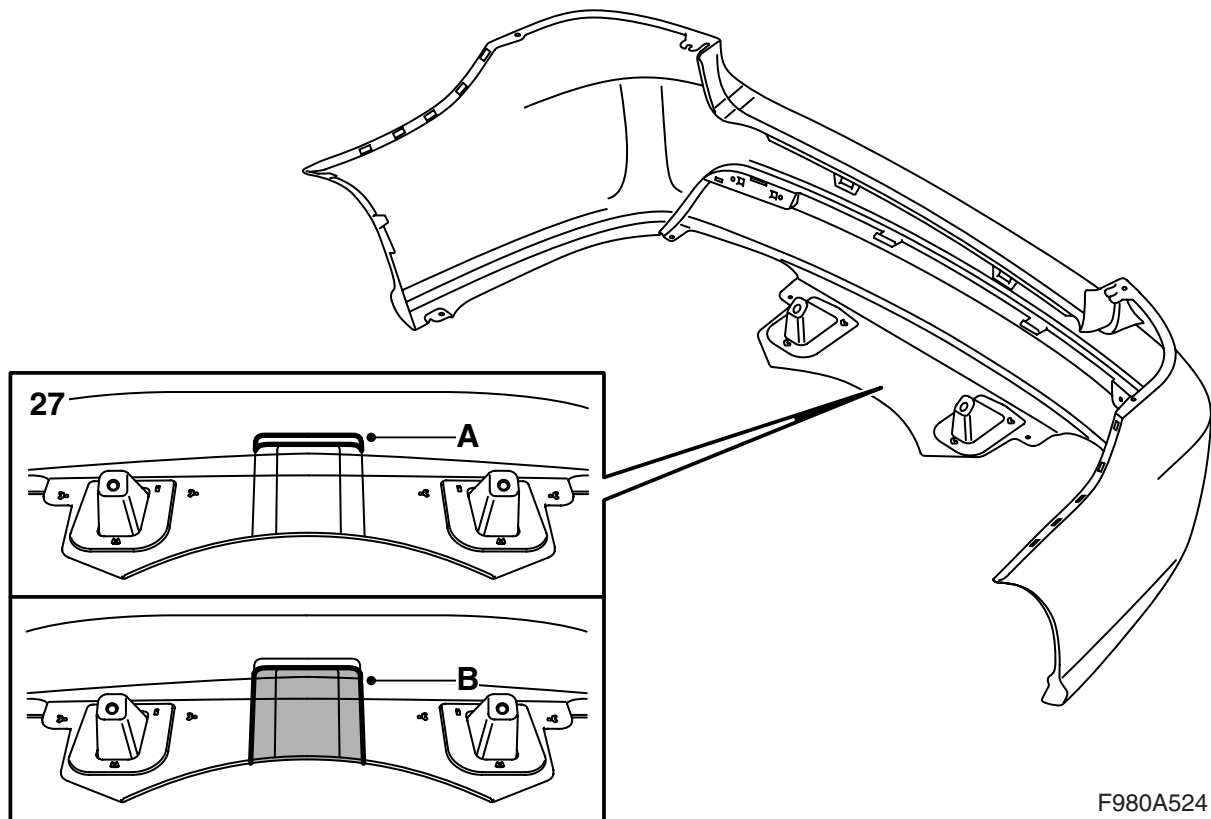

F980A524

### 27 M08, cars without bumper skirt:

27.1 Print out template 1 and cut out the template.

#### Important

Check that the size of the template corresponds with the specified dimensions after printing it out.

Create your own template if it is not possible to make the printout correspond with the specified dimensions.

27.2 Position template 1 (A) on the inside of the bumper shell against the upper marking and draw around the lower edge of the template.

27.3 Cut/saw from the inside of the bumper shell (B).

#### **WARNING**

Use of a saw and knife entails a risk of injury. Exercise caution when cutting. Check that the bumper shell is stably positioned before beginning to cut. Use personal protection equipment, such as protective gloves, safety goggles and hearing protection.

#### Note

The cut-out may need to be adapted to the tow-bar after fitting. Check that there is a small amount of play between towbar and bumper.

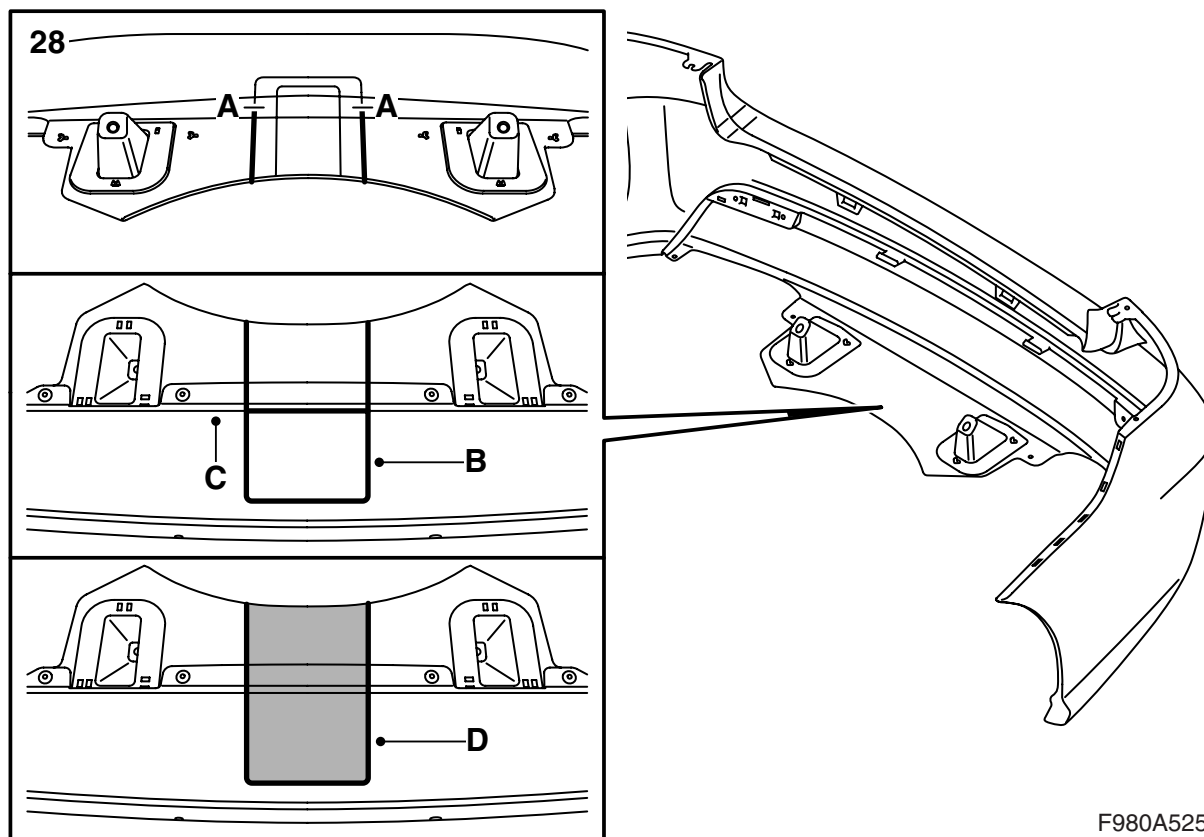

F980A525

## 28 M08, cars with bumper skirt:

28.1 Print out template 2 and cut out the template.

### Important

Check that the size of the template corresponds with the specified dimensions after printing it out.

Create your own template if it is not possible to make the printout correspond with the specified dimensions.

28.2 Saw from the inside of the bumper in accordance with the outer markings up to (A).

28.3 Turn the bumper over.

28.4 Position template 2 (B) on the outside of the bumper skirt against the edge (C). Centre between the sawn grooves and draw around the template.

28.5 Saw from the outside of the bumper skirt in accordance with the marking (D).

### WARNING

Use of a saw and knife entails a risk of injury. Exercise caution when cutting. Check that the bumper shell is stably positioned before beginning to cut. Use personal protection equipment, such as protective gloves, safety goggles and hearing protection.

### Note

The cut-out may need to be adapted to the towbar after fitting. Check that there is a small amount of play between towbar and bumper.

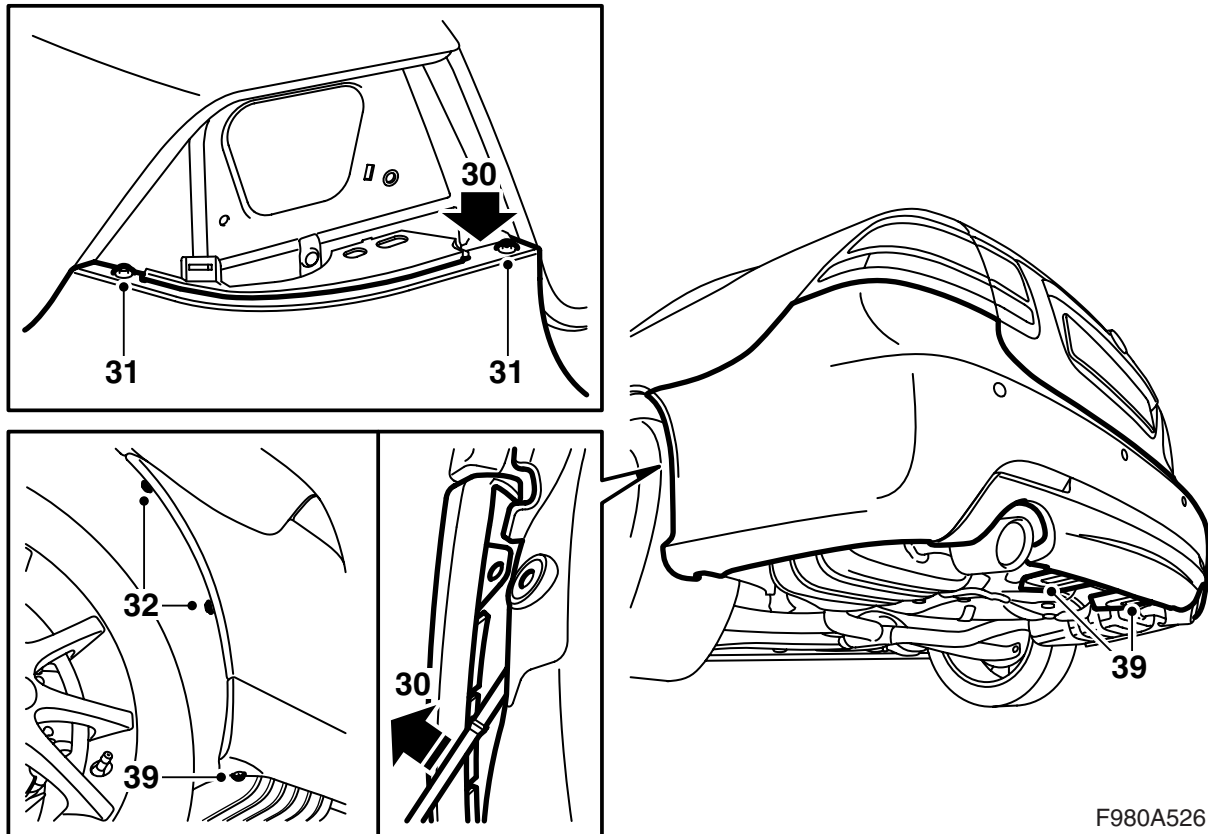

F980A526

- 29 **SPA:** Insert and plug in the connector.
- 30 Fit in the two tabs of the bumper shell under the holders and the outer corners between the wheel arch liner and the mounting points at the wheel arches. Press the bumper shell into place.
- 31 Fit the bumper shell bolts that are located below the rear lamp clusters.
- 32 Fit the bumper bolts at the wheel housings.
- 33 Fit and connect the rear lamp clusters. Check the fit against the boot lid moulding.
- 34 Fit the left-hand side trim.  
**CV:** Connect the luggage compartment lighting and hook the strap on.
- 35 Fit the side scuff plate on the left-hand side.
- 36 Fit the scuff plate.
- 37 **4D:** Fit the hatches in the luggage compartment side trims.  
**CV:** Fit the carpet on the luggage compartment floor.
- 38 Raise the car.
- 39 Fit the two nuts holding the air shield of the rear bumper against the body. Fit the two screws holding the bumper shell against the wheel housings.

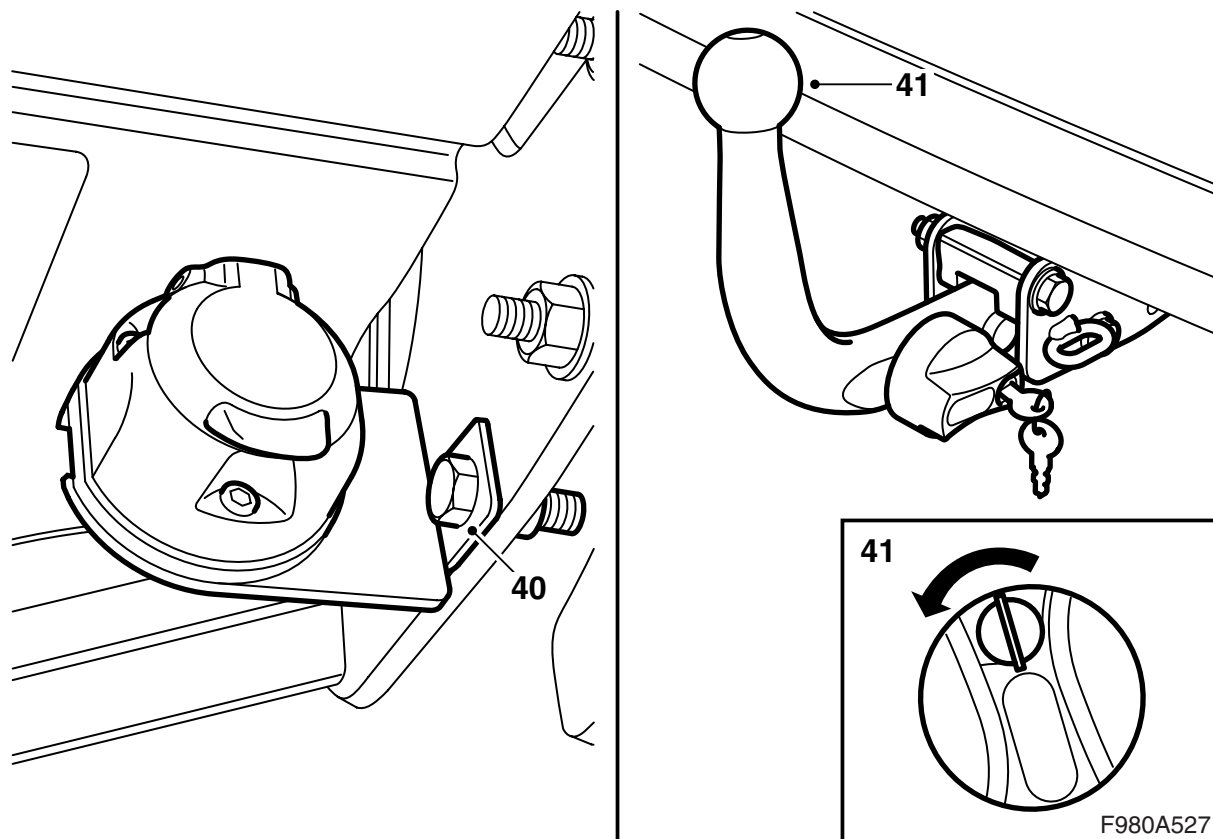

- 40 Fit the connector holder plate with connector to the towing bracket.
- 41 Mount the ball unit by fitting it into place and pressing it forwards and downwards so that the knob is automatically turned anti-clockwise and the lock is activated. Turn the key anti-clockwise and remove it.

**⚠ WARNING**

Green should be the only colour shown in the socket at the knob.

Tug on the ball unit to make sure it is properly secured.

- 42 Lower the car and check the bumper alignment. Adjust if necessary.
- 43 Carefully remove the user instruction page and give it to the customer together with the installation instructions.



**List of components**

<b>No.</b>	<b>Name position</b>
<b>Components</b>	
13	Lamp, parking light, trailer
22	Main dashboard fuse box, on the short side of the instrument panel near the left-hand door
27	Lamp, direction indicators, trailer
30	Lamp, brake lights, trailer
32	Lamp, reversing lights, trailer
33	Lamp, rear fog lights, trailer
258	Connector, towbar wiring harness, in the luggage compartment electrical distri- bution box
701	Luggage compartment electrical distribution box, on the wall behind the left rear wheel housing
731	Trailer control module, in the luggage compartment electrical distri- bution box
<b>102-pin connector</b>	
H102-1	Lower left-hand A-pillar
<b>Crimp connections</b>	
J	Approx. 160 mm from the 13-pin connector
J67	<b>LHD:</b> Approx. 150 mm from branching point front left floor lighting towards connector H102-1 <b>RHD:</b> Approx. 50 mm from branching point grounding point G40 towards grounding point G41
<b>Grounding points</b>	
G3	In the luggage compartment below the left- hand light cluster





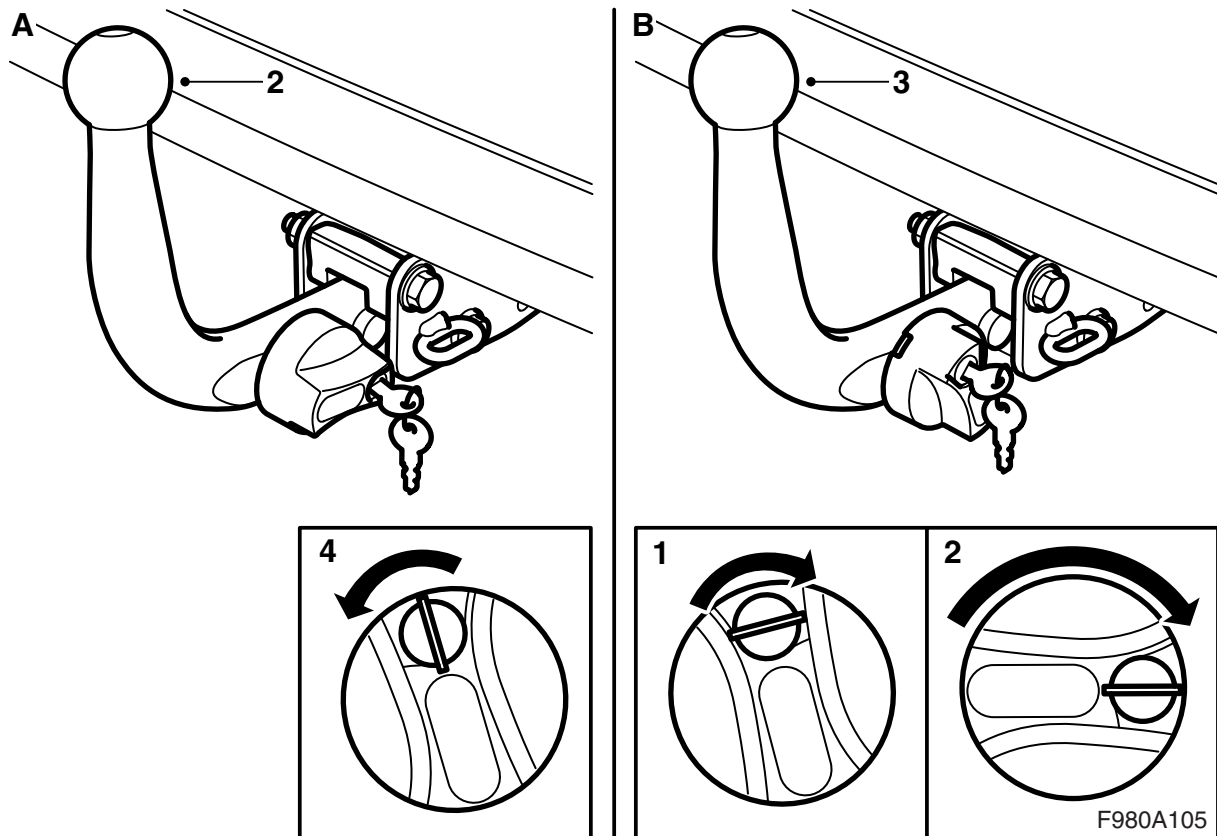

#### User instructions(keep in the car's Owners Manual)

#### **WARNING**

To ensure that the towbar is coupled **correctly and safely**:

- The coupling mechanism must **always** be well lubricated. Contact your nearest Saab dealer regarding which grease is appropriate.
- Always** fit the protective cover when the towball unit is not attached.
- It must **always** be possible to detach and attach the towball unit without it jamming.

#### **Important**

If the trailer is equipped with extra electrical equipment in addition to normal outer lighting (e.g. inner lighting or fan) and connected to the car via the trailer's connector, the trailer must be equipped with a 13-pin connector (installed according to ISO 11446) in order to allow for a separate power supply.

#### **Important**

**Cars with SPA:** The SPA system will compensate for the towbar in measuring the distance behind the car irrespective of whether the ball unit is fitted.

#### **A. Fitting the ball unit**

- 1 Remove the protective cover.
- 2 Fit the ball unit into the bracket.
- 3 Press the ball unit forward and downward so that the knob is automatically turned anticlockwise and the lock is activated.
- 4 Turn the key anticlockwise and remove it.

#### **WARNING**

Green should be the only colour shown in the socket at the knob.

Tug on the ball unit to make sure it is properly secured.

#### **B. Removing the ball unit**

- 1 Insert the key in the lock and turn it clockwise.
- 2 Press in the knob and turn it clockwise until it meets resistance and an audible "click" is heard.
- 3 Lift the ball unit up and pull it rearwards.
- 4 Fit the protective cover.

#### **Important**

When the ball unit is removed, the protective collar must be fitted on the ball unit knob in order to protect the key.



Template 1

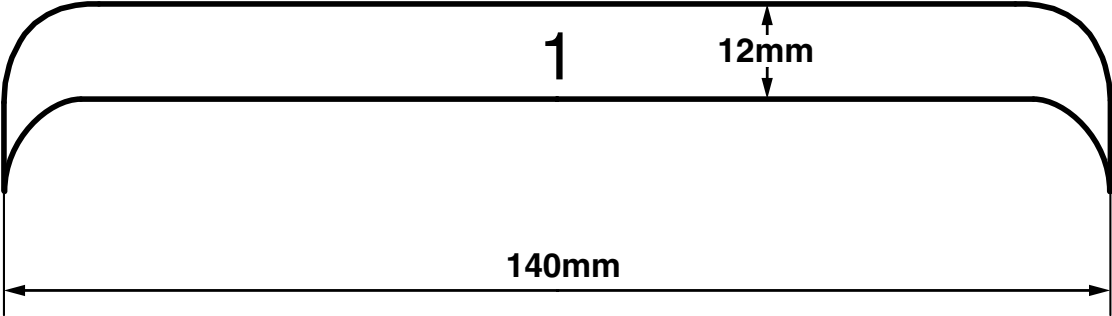

F980A514



**Template 2**

